

BT 研磨螺栓拉頭

BT HIGH STRENGTH PULL STUD

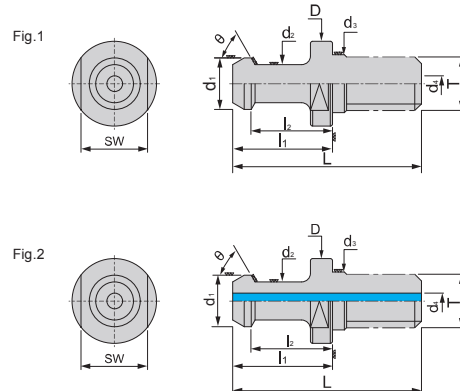

特點 Feature

- 外徑研磨加工以兩頂心孔做研磨牙級的中心點，減少累計公差，減少偏擺

- Grinding the external thread by using the support of two live centers to reduce the accumulated tolerance and runout.

規格 Spec.	L	l ₁	l ₂	D	d ₁	d ₂	d ₃	d ₄	SW	T	Fig.	θ	重量 (KGS) Weight
BT30- 45° -G	43	23	18	16.5	11	7	12.5	-	13	M12x1.75P	1	45°	0.05
BT30- 60° -G	43	23	18	16.5	11	7	12.5	-	13	M12x1.75P	1	60°	0.05
BT30- 90° -G	43	23	18	16.5	11	7	12.5	-	13	M12x1.75P	1	90°	0.05
BT40- 45° -G	60	35	28	23	15	10	17	-	19	M16x2.0P	1	45°	0.10
BT40- 60° -G	60	35	28	23	15	10	17	-	19	M16x2.0P	1	60°	0.10
BT40- 90° -G	60	35	28	23	15	10	17	-	19	M16x2.0P	1	90°	0.10
BT50- 45° -G	85	45	35	38	23	17	25	-	30	M24x3.0P	1	45°	0.28
BT50- 60° -G	85	45	35	38	23	17	25	-	30	M24x3.0P	1	60°	0.28
BT50- 90° -G	85	45	35	38	23	17	25	-	30	M24x3.0P	1	90°	0.27
BT30- 45° -HG (2x3)	43	23	18	16.5	11	7	12.5	2x3	13	M12x1.75P	2	45°	0.03
BT30- 60° -HG (2x3)	43	23	18	16.5	11	7	12.5	2x3	13	M12x1.75P	2	60°	0.03
BT40- 45° -HG (4)	60	35	28	23	15	10	17	4	19	M16x2.0P	2	45°	0.07
BT40- 60° -HG (4)	60	35	28	23	15	10	17	4	19	M16x2.0P	2	60°	0.07
BT40- 90° -HG (4)	60	35	28	23	15	10	17	4	19	M16x2.0P	2	90°	0.07
BT40- 45° -HG (5)	60	35	28	23	15	10	17	5	19	M16x2.0P	2	45°	0.07
BT40- 60° -HG (5)	60	35	28	23	15	10	17	5	19	M16x2.0P	2	60°	0.07
BT50- 45° -HG (7)	85	45	35	38	23	17	25	7	30	M24x3.0P	2	45°	0.25
BT50- 60° -HG (7)	85	45	35	38	23	17	25	7	30	M24x3.0P	2	60°	0.25
BT50- 90° -HG (7)	85	45	35	38	23	17	25	7	30	M24x3.0P	2	90°	0.25
■ BT50 - 45°	85	45	35	38	23	17	25	-	30	M24x3.0P	1	45°	0.30
■ BT50 - 60°	85	45	35	38	23	17	25	-	30	M24x3.0P	1	60°	0.30
■ BT50 - 90°	85	45	35	38	23	17	25	-	30	M24x3.0P	1	90°	0.30

■ 無研磨 Grind

- 中心給水規格 (4)&(7) 可以通過 3mm&6mm 六角扳手

- Center coolant specification (4) & (7) can use with the hex wrench 3mm & 6mm