

BT / ER COLLET CHUCK



BT / ER 立銑刀夾頭

(DIN ISO 15488)



TW PAT NO. M298033
 TW PAT NO. M311791
 J P PAT NO. 3128766
 K R PAT NO. 20-0433603
 C N PAT NO. ZL200620132661.0
 C H PAT NO. 696550
 T R PAT NO. TR 2007 02942 Y
 I T PAT NO. N.0000266731

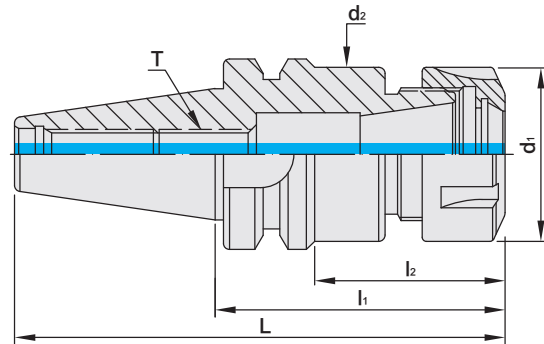

MODEL NO.	TYPE	L	l ₁	l ₂	d ₁	d ₂	T	SIZE RANGE	WEIGHT (KGS)
5011-108-016-070	BT40 x ER16A - 70	135.4	70	40	28	28	M10 x 1.5P	1 ~ 10	1.20
5011-108-016-090	BT40 x ER16A - 90	155.4	90	60.5	28	28	M10 x 1.5P	1 ~ 10	1.16
5011-108-016-100	BT40 x ER16A - 100	165.4	100	63	28	28	M10 x 1.5P	1 ~ 10	1.30
5011-108-016-120	BT40 x ER16A - 120	185.4	120	83	28	28	M10 x 1.5P	1 ~ 10	1.28
5011-108-016-125	BT40 x ER16A - 125	190.4	125	88	28	28	M10 x 1.5P	1 ~ 10	1.36
5011-108-016-150	BT40 x ER16A - 150	215.4	150	113	28	28	M10 x 1.5P	1 ~ 10	1.54
5011-108-016-180	BT40 x ER16A - 180	245.4	180	143	28	28	M10 x 1.5P	1 ~ 10	2.00
5011-108-016-200	BT40 x ER16A - 200	265.4	200	163	28	28	M10 x 1.5P	1 ~ 10	1.57
5011-108-020-070	BT40 x ER20A - 70	135.4	70	40	34	34	M12 x 1.75P	1 ~ 13	1.20
5011-108-020-090	BT40 x ER20A - 90	155.4	90	53	34	34	M12 x 1.75P	1 ~ 13	1.28
5011-108-020-100	BT40 x ER20A - 100	165.4	100	63	34	34	M12 x 1.75P	1 ~ 13	1.80
5011-108-020-120	BT40 x ER20A - 120	185.4	120	83	34	34	M12 x 1.75P	1 ~ 13	1.46
5011-108-020-135	BT40 x ER20A - 135	200.4	135	98	34	34	M12 x 1.75P	1 ~ 13	1.70
5011-108-020-150	BT40 x ER20A - 150	215.4	150	113	34	34	M12 x 1.75P	1 ~ 13	1.80
5011-108-020-200	BT40 x ER20A - 200	265.4	200	163	34	34	M12 x 1.75P	1 ~ 13	1.87
5011-108-020-250	BT40 x ER20A - 250	315.4	250	213	34	34	M12 x 1.75P	1 ~ 13	2.17
5011-110-025-070	BT40 x ER25 - 70	135.4	70	40	42	42	M16 x 2.0P	1 ~ 16	1.30
5011-110-025-090	BT40 x ER25 - 90	155.4	90	60	42	42	M16 x 2.0P	1 ~ 16	1.34
5011-110-025-100	BT40 x ER25 - 100	165.4	100	70	42	42	M16 x 2.0P	1 ~ 16	1.50
5011-110-025-120	BT40 x ER25 - 120	185.4	120	90	42	42	M16 x 2.0P	1 ~ 16	1.67
5011-110-025-125	BT40 x ER25 - 125	190.4	125	95	42	42	M16 x 2.0P	1 ~ 16	1.80
5011-110-025-150	BT40 x ER25 - 150	215.4	150	115	42	42	M16 x 2.0P	1 ~ 16	2.10
5011-110-025-200	BT40 x ER25 - 200	265.4	200	165	42	42	M16 x 2.0P	1 ~ 16	2.32

Features:

- ▶ According to DIN ISO 15488.
- ▶ This ER collet chuck has superior flexibility for use with all tool types, e.g. drills, taps, mills, reamers.
- ▶ It is recommended to tighten the clamping nuts using a torque wrench. Refer to NO.75 General Catalog- Accessories for the info. of recommended tightening torque.

Product information:

- ▶ AD+B type is available, please inform us when making an order.

Standard Accessory: • NUT

Collet	Nut	Pull Stud	Preset Screw	Spanner	Torque Wrench Adapter (Pull Stud)	Spanner (Pull Stud)
P.W-11~34	P.W-55~59	P.W-67~68	P.W-107	P.W-75-77、79、81	P.W-78	P.W-82