

規格 Spec.	L	l ₁	l ₂	D	d ₁	d ₂	d ₃	SW	T	重量 (KGS) Weight
ISO20- 15°	26	12	9	12	9	6	8.5	10	M8	0.10
ISO25- 15°	28	16	11.7	12	10	7	8.5	10	M8	0.10
ISO25- 45°	31	18	13.5	12	10	7	9	10	M8	0.10
ISO30- 45°	45	24	19	17	12.8	9	13	14	M12	0.30

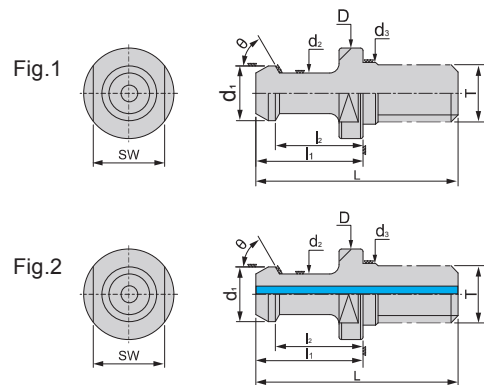

特點 Feature

- HS 系列硬度可達到 HRC60°
- 外徑研磨加工以兩頂心孔做研磨牙級的中心點，減少累計公差，減少偏擺

- HS series degree of hardness may achieve HEC60°.
- Grinding the external thread by using the support of two live centers to reduce the accumulated tolerance and runout.

規格 Spec.	L	l ₁	l ₂	D	d ₁	d ₂	d ₃	SW	T	θ	Fig.	重量 (KGS) Weight
BT30- 45° -HS	43	23	18	16.5	11	7	12.5	13	M12x1.75P	45°	1	0.03
BT30- 60° -HS	43	23	18	16.5	11	7	12.5	13	M12x1.75P	60°	1	0.03
BT40- 45° -HS	60	35	28	23	15	10	17	19	M16x2.0P	45°	1	0.08
BT40- 45° -HS-W	60	35	28	23	15	10	17	19	M16x2.0P	45°	2	0.08

• 長度單位 Unit of Length (mm)